

Mobile Cart Computer

Venus-243

24" 24/7 Self-Power Medical Cart Computer

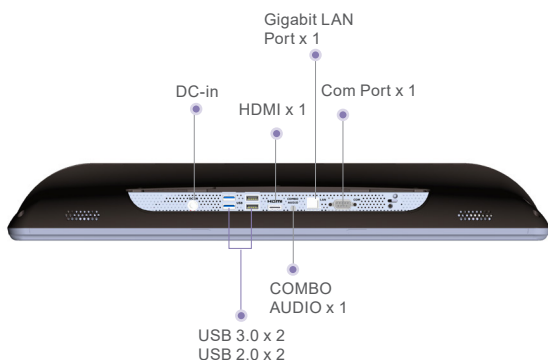
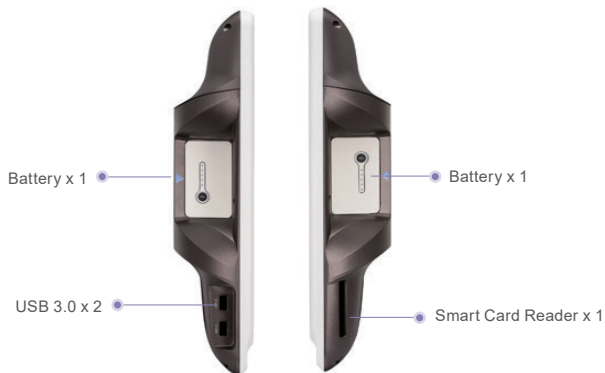

Features

- Highest level of medical safety protection , EMC4.0/ Safety 3.1
- Cleanability with Hospital Solvents (front IP65)
- Hot swappable design, support 24/7 run time
- Intel® Skylake Dual-Core i5
- Support remote monitor/control/update (ORION compatible)
- Lightweight design
- HDMI 1.4
- Win10 64 bit compatible

Specifications

Main Specifications

Processor	Intel® Skylake Dual-Core i5
System Memory	DDR4 up to 32GB
OS Support	Microsoft® Windows 7 (32/64bit) Microsoft® Windows 8.1 (64bit) Microsoft® Windows 10 (64bit) Ubuntu 14.04 LTS IGEL (thin client solution)
Graphics	Intel® HD Graphics 520
Storage	SSD up to 512GB (optional)
Wireless Communication	802.11 ac/a/b/g/n + BT (optional)
Touch	PCT
Speaker	2W x2
Security	TPM 2.0 (Trusted Platform Module), Smart Card Reader, RFID ISO 15693/14443A (optional)

Display

Display Size	23.8" VA panel
Resolution	1920 x 1080
Max. Colors	16.7M
Contrast Ratio	3000:1
Luminance (cd/m2)	250

I/O

USB	Rear I/O: USB 3.0 x 2, USB 2.0 x 2 Side I/O : USB 3.0 x 2
Video Out	HDMI 1.4 x1
COM	COM port x1
Audio	Combo audio port x1
Security	Kensington slot
Ethernet	Gigabit LAN x1
DC-in	24V DC-in x1

Mechanical and Environmental

VESA	75/100 mm VESA mount
Operating Temperature	0°C ~ 40°C(32°F ~ 104°F)
Storage Temperature	-20°C ~ 60°C(-4°F ~ 140°F)
Storage Humidity	10%~95%@35°C, non-condensing
Dimension	528(L) x 78(W) x 404(H) mm
Net Weight w/o Battery	8kg (17.6 lbs)
Net Weight w/ XL Battery	9kg (19.84lbs)
Packing Size	745(L) x 255(W) x 558(H) mm
Gross Weight	11.5kg (24.3 lbs)

Certifications	CE: EN 60601-1-2:2015(V4.0), EN 60601-1:2006/ A1:2013(V3.1)
	FCC: Part 18 Class B
	UL: ANSI/AAMI ES60601-1:2012 (V3.1)
	cUL: CAN/CSA-C22.2 No. 60601-1:2014 (V3.1)

ALL PRODUCT, PRODUCT SPECIFICATIONS AND DATA ARE SUBJECT TO CHANGE WITHOUT NOTICE TO IMPROVE RELIABILITY, FUNCTION OR DESIGN OR OTHERWISE.

※ All product specifications are subject to change without notice



www.onyxhealthcareusa.com

Dimension / Unit: mm

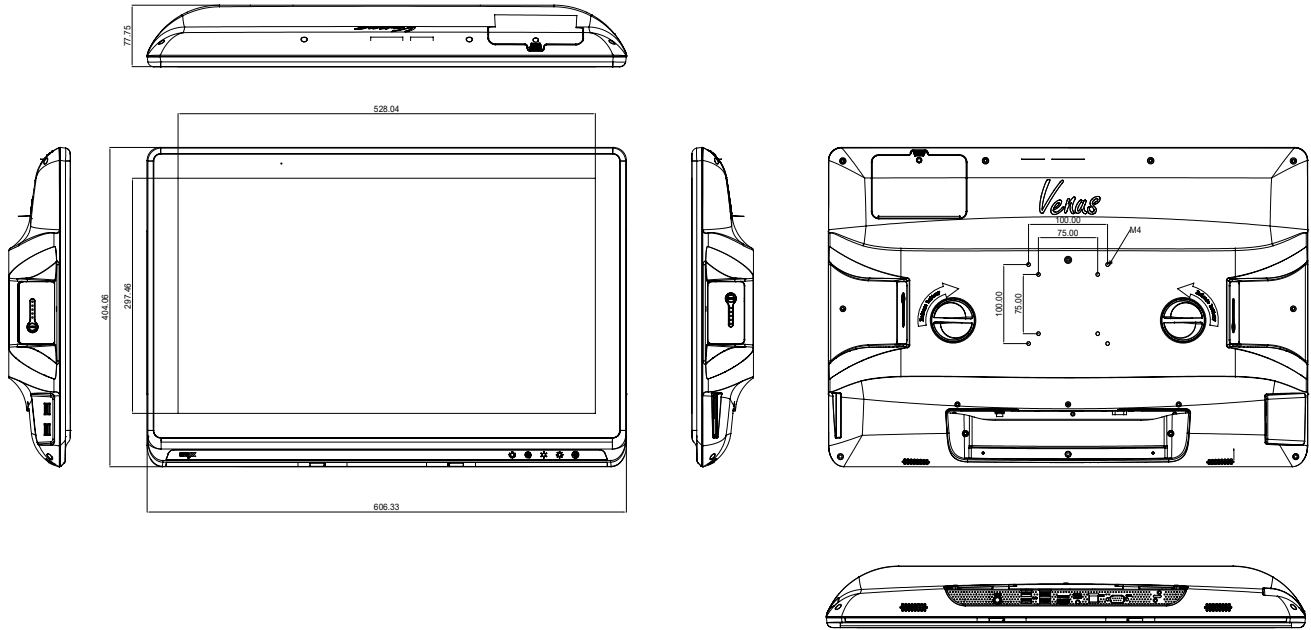

Ordering Information

- » VENUS-243ST-A5-1010
Cart Computer.i5.24".Fanless.PCT.4G RAM.SCR.TPM. XL Battery x2

Optional Accessories

- » **1255301501**
Medical Adaptor. 100-240V/1.0-2.5A 24V/6.25A 150W
- » **968C128G3H**
128G 2.5" SSD
- » **OPM-S02R-A1**
RFID Reader Kit
- » **OPM-C10W-A0**
WLAN dual band module kits. INTEL 802.11ac/a/b/g/n+BT
- » **OPM-C07W-A2**
WLAN dual band module kits. Atheros 802.11a/b/g/n + BT 4.0
- » **UP-L62-A1-1010**
6-Slot Charger + 24V/250W adaptor
- » **UP-P22-A2-1010**
2-Slot Charger + 24V Medical adaptor

※ All product specifications are subject to change without notice