

Mobile Cart Computer

Venus-193

19" 24/7 Self-Power Cart Computer

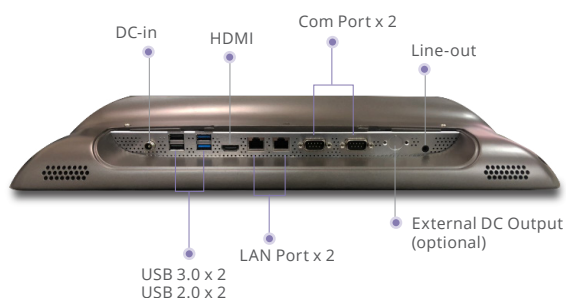
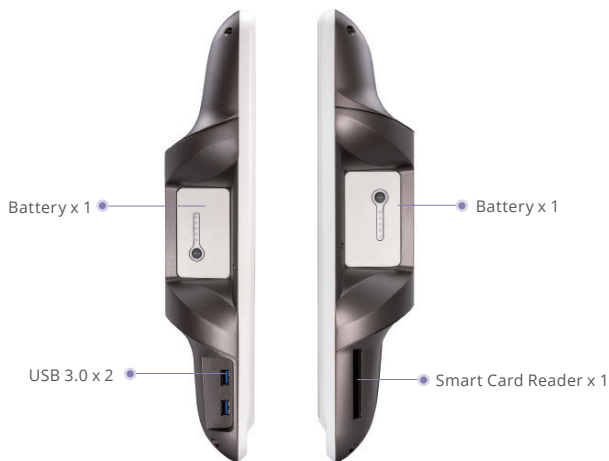

Features

- Highest level of medical safety protection
- Cleanability with hospital solvents (front IP65)
- Hot swappable design, support 24/7 run time
- Intel® Skylake Dual-Core i5 / Celeron 3955U
- Support remote monitor/control/update (ORION compatible)
- Lightweight design
- Front reading light bar

Specifications

Main Specifications

Processor	Intel® Skylake Dual-Core i5 / i7 , Celeron 3955U
System Memory	DDR4 up to 32GB
OS Support	Microsoft® Windows 7 Microsoft® Windows 8.1 Microsoft® Windows 10 (64bit) Ubuntu 18.04 LTS IGEL (thin client solution)
Graphics	Intel® HD Graphics 520
Storage	SSD up to 512GB (optional)
Wireless Communication	802.11 ac/a/b/g/n + BT 4.0 (optional)
Touch	R-TS
Speaker	2W x2
Security	TPM 2.0 Smart Card Reader, RFID ISO 15693/14443A (optional)
Auto Brightness	Light sensor

Display

Display Size	19" panel
Resolution	1280 x 1024
Max. Colors	16.7M
Contrast Ratio	1000:1
Luminance (cd/m2)	250

I/O

USB	Rear I/O :USB 3.0 x2, USB 2.0 x2Side I/O : USB 3.0 x2
Video Out	HDMI 1.4 x1
COM	COM port x2
Audio	Combo audio port x1
Ethernet	Gigabit LAN x2
DC-in	24V DC-in x1

Mechanical and Environmental

VESA	75/100 mm VESA mount
Operating Temperature	0°C ~ 35°C(32°F ~ 95°F)
Storage Temperature	-20°C ~ 60°C(-4°F ~ 140°F)
Storage Humidity	10%~95%@40°C, non-condensing
Dimension	429(L) x 78(W) x 384(H) mm
Net Weight	5.5kg (12.13 lbs)
Packing Size	540(L) x 205(W) x 503(H) mm
Gross Weight	9kg (19.84 lbs)
Certifications	CE: EN 60601-1-2:2015(V4.0), EN 60601-1:2006/ A1:2013(V3.1) FCC: Part 18 Class B UL: ANSI/AAMI ES60601-1:2012 (V3.1) cUL: CAN/CSA-C22.2 No. 60601-1:2014 (V3.1)

ALL PRODUCT, PRODUCT SPECIFICATIONS AND DATA ARE SUBJECT TO CHANGE WITHOUT NOTICE TO IMPROVE RELIABILITY, FUNCTION OR DESIGN OR OTHERWISE.